



SMITH
FLOW CONTROL LTD

SFC KEY INTERLOCKS & PROCESS MANAGEMENT SYSTEMS



QL VALVE INTERLOCKS For lever operated valves

QL VALVE INTERLOCK (QLT & QLR)

QL valve (inter)locks suit all types of lever-operated quarter-turn valves - including Ball, Butterfly and Plug valves.

Installing the (inter)lock on the host valve is a simple procedure as described below and requires no modification or hot-work to the host equipment as the anchor and adaptors are custom-machined to suit the valve.

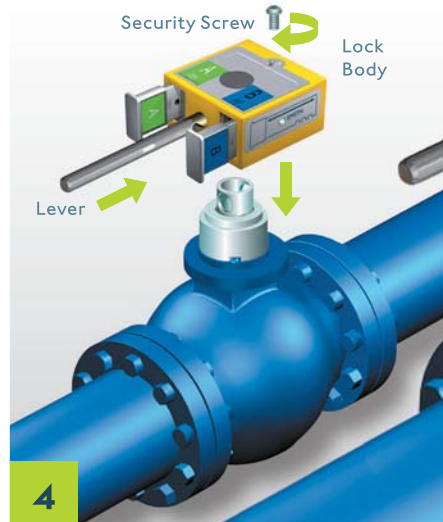
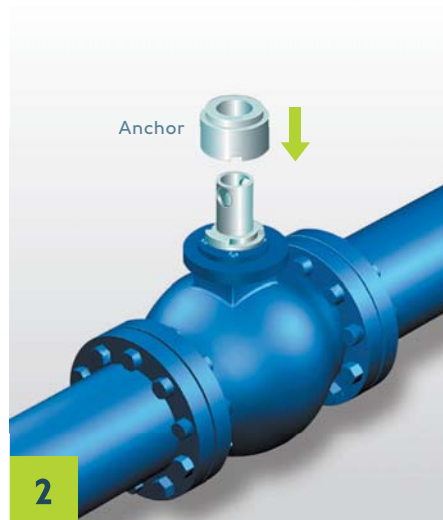
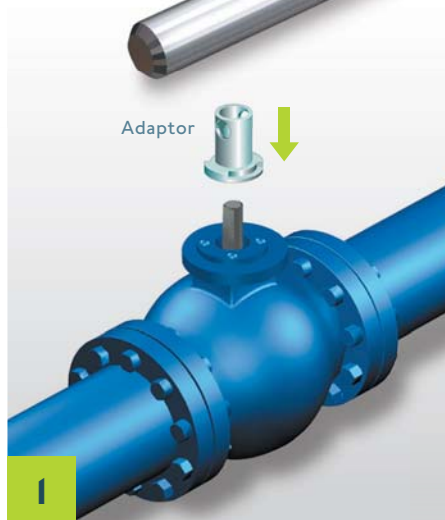
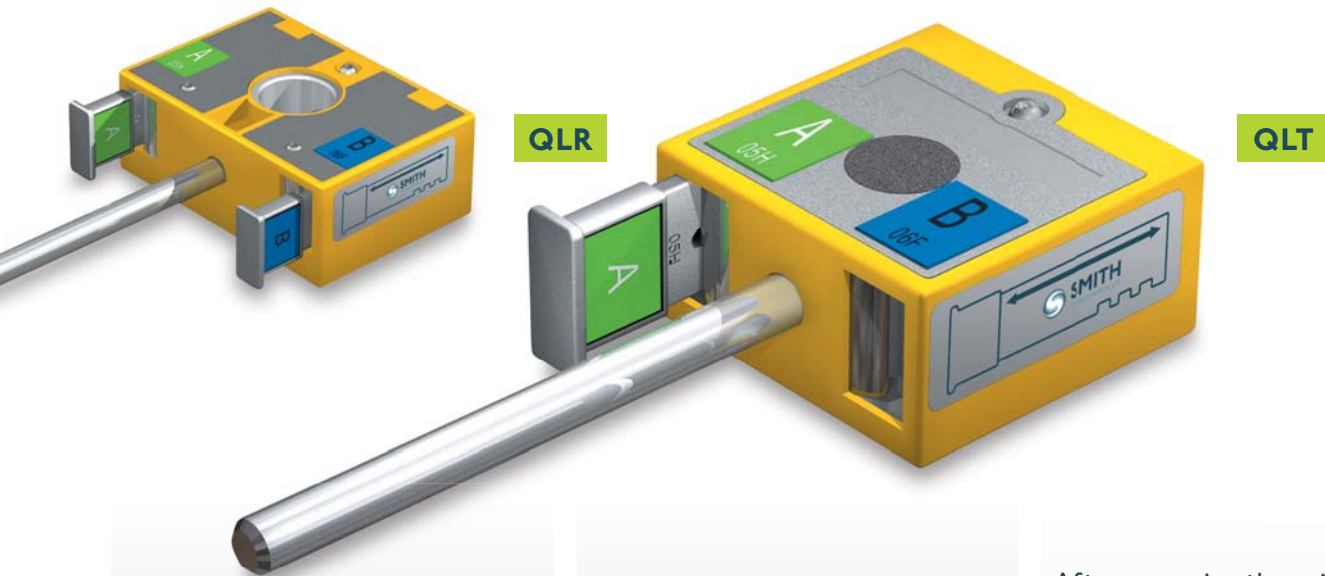

After removing the existing Lever the QL is assembled as follows:

- 1 Install lock adaptor.
- 2 Install anchor.
- 3 Fit SFC nut.
- 4 Assemble QL lock, secure lever and tighten screw.

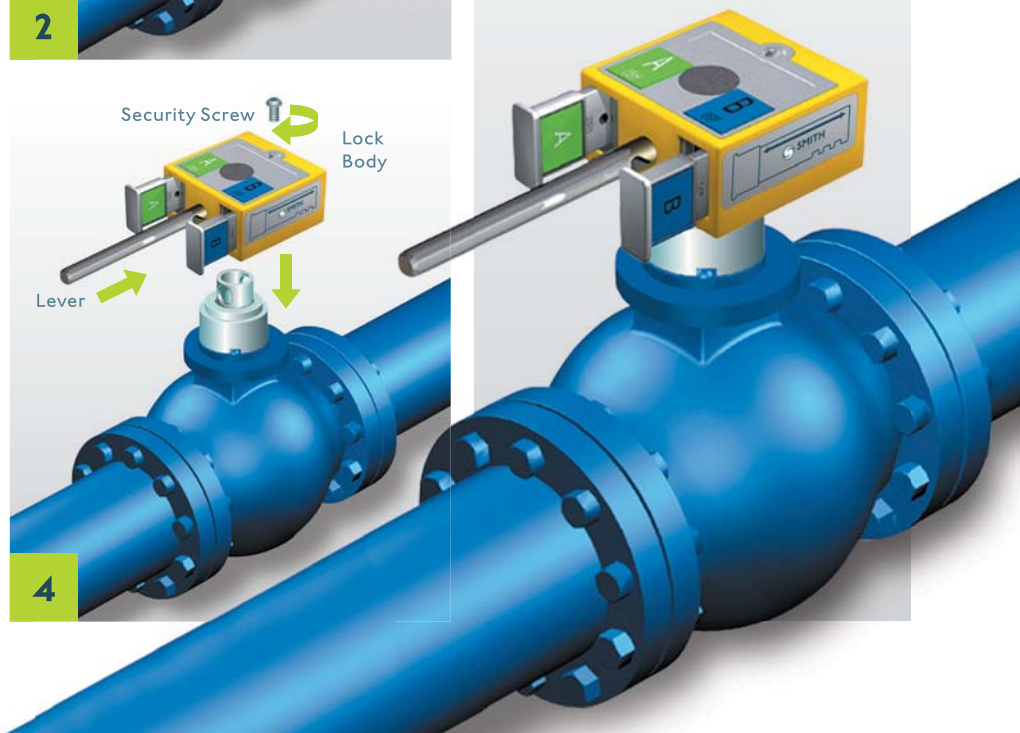

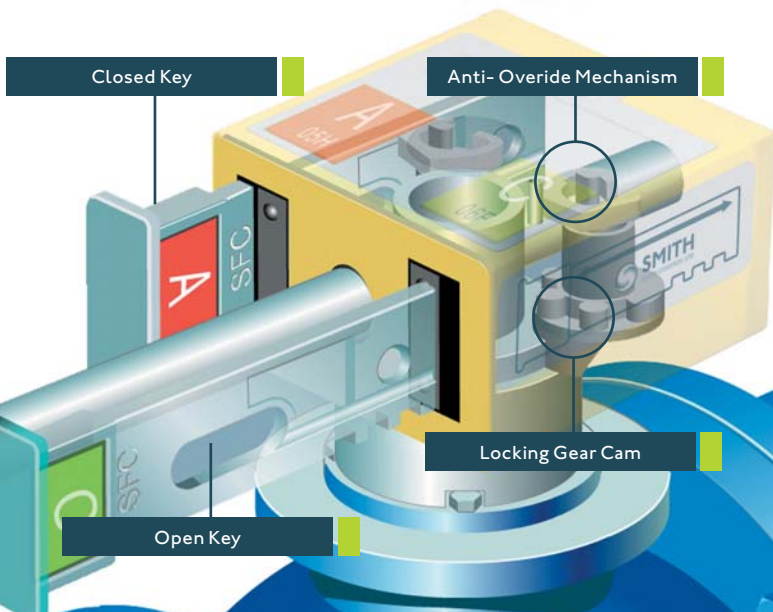
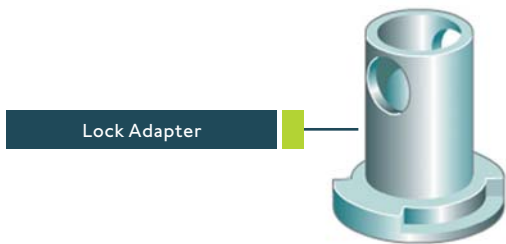
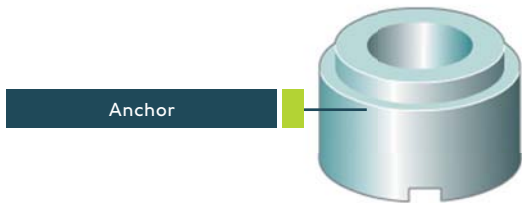
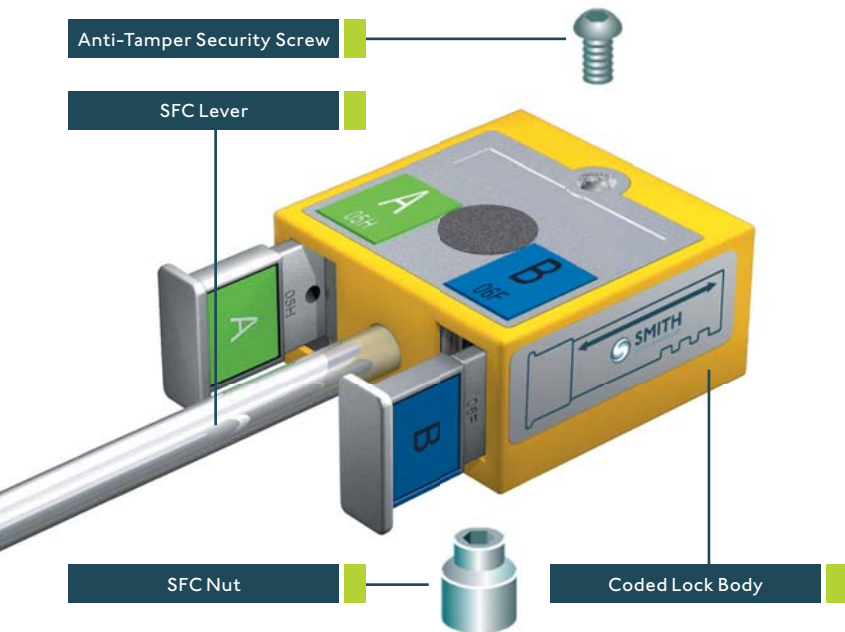

PRODUCT FEATURES

- 316 Stainless steel.
- Linear 'coded-card' key design.
- Robust construction.
- Proven reliability in all climates.
- Single or double key versions.

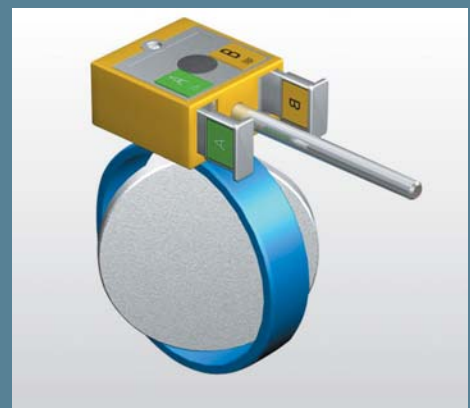
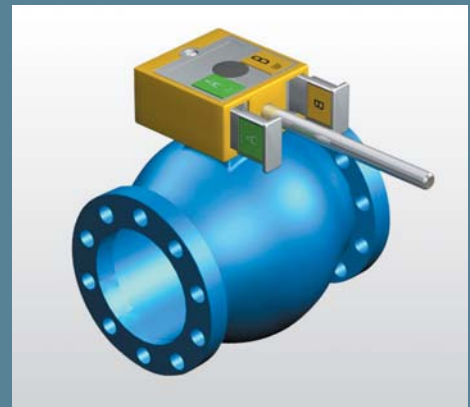

- No modification to host valve.
- Suitable for any valve type/model.
- Can be installed on 'live' plant.