

KTM METALTITE[®] BALL VALVES
 FLOATING AND TRUNNION TYPE

Metaltite[®] metal seated ball valves have excellent sealing characteristics suitable for various fluids services with a wide range of operating temperatures

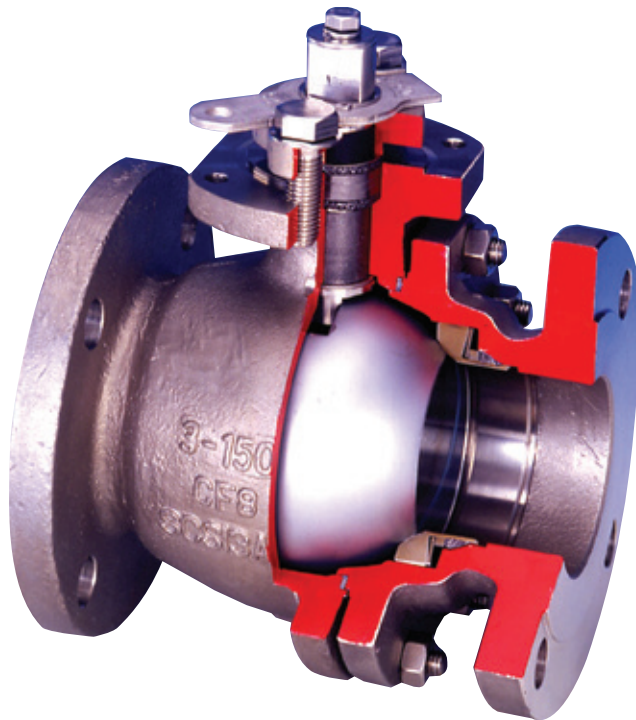

FEATURES

- High precision machining results in superior ball and seat interfacing for tight shutoff conforming to ANSI / FCI 70-2 Class V (Class VI as option)
- Spring loaded seat maintains close contact with the ball assuring tight sealing even at low pressures. This results in stable opening and closing torques at high differential pressures over a wide range of temperatures
- The combination of metal seats and graphite seals ensure fire-safe capabilities
- Various material components are available for a variety of service application up to 500°C
- Uniquely designed trunnion mounted valves are also available for powder service
- KTM can provide a complete valve and actuator as 'package' for special applications including powder and super speed applications
- Surface-hardened ball and seats allow use in more severe applications such as slurries, pulp stock and other abrasive media in long life
- Ball surface hardening process can be chosen. (For details, please refer to page 2)
 Hard chrome plating
 Nickel alloy overlay
 Tungsten carbide
 Chrome carbide

GENERAL APPLICATION

Clean fluids, dirty fluids, high viscosity, scaling fluids, corrosive, erosive, waste treatment, sludge, saturated steam, super-heated steam, high temperature, high velocity, powder (PP,PE)

Options

- Ball surface hardening process
- Extension bonnet
- Jacketed ball valve
- Special tests
 X-ray (RT)
 Liquid penetrant (PT)
 Positive material identification (PMI)

TECHNICAL DATA

Models:	EB11M, EB12M, E0105M, E0106M, E0125M, E0126M, E0108M, E0109M
Sizes:	15 mm to 500 mm (½" to 20")
Pressure rating:	JIS 10K, 20K ASME Class 150 to 900 (JPI available)
Face to face:	JIS B2002 / ASME B16.10
End connection:	JIS B2220 / ASME B16.5
Temperature:	-29°C to 500°C (Up to 450°C for oxidizing conditions)

KTM METALTITE® BALL VALVES

FLOATING AND TRUNNION TYPE

PIONEER IN THE METAL SEATED BALL VALVE

Experience gained from over 40 years of manufacturing metal-seated ball valves has contributed to the development of a valve of superior quality and design Metalltite®. Precision lapping of the ball-to-seat results in superior interfacing and a tight shut-off conforming to ANSI / FCI 70-2 Class V and Class VI as option.

KTM utilizes proprietary processes with special lapping technologies, enabling us to provide a higher-quality product with a superior level of performance.

TECHNICAL SPECIFICATION

Type	Manufacturing range ^[1]	Temperature range ^[1]	Seat gasket / seal ring	Hard-facing ^[4]	Trim code ^[5]	Applications
Floating	Class 150, 300 DN 15 to 200 (NPS ½ to 8)	-29°C to 250°C (-20°F to 480°F)	R-PTFE	Ball: Hard chrome plated Seat: Stellite	AY ^[6]	Slurries, pulp stock, solid-containing fluids, etc. ON-OFF or throttling.
				Ball: Nickel alloy overlay Seat: Stellite	BY	
	Class 600 DN 15 to 40 (NPS ½ to 1½)	-29°C to 350°C (-20°F to 662°F)	Graphite	Ball: Hard chrome plated Seat: Stellite	AG ^[6]	High-temperature fluids, slurry, pulp stock, steam, solid containing fluids, etc. ON-OFF or throttling, fire-safe.
				Ball: Nickel alloy overlay Seat: Stellite	BG	
			Graphite	Ball: Nickel alloy overlay Seat: Stellite	BX	High-temperature, high-frequency, high-pressure services, fire-safe.
Trunnion	Class 150, 300 DN 50 to 500 (NPS 2 to 20)	-20°C to 150°C (-4°F to 300°F)	FKM O-ring	Ball: Hard chrome plated Seat: Stellite	AY ^[6]	Slurries, pulp stock, solid-containing fluids, etc. ON-OFF or throttling.
				Ball: Nickel alloy overlay Seat: Stellite	BY	
	Class 600 DN 50 to 400 (NPS 2 to 16)	-29°C to 250°C (-20°F to 480°F)	PTFE seal ring	Ball: Hard chrome plated Seat: Stellite	AG ^[6]	Slurries, pulp stock, steam, solid containing fluids, etc. ON-OFF or throttling, fire-safe.
				Ball: Nickel alloy overlay Seat: Stellite	BG	
				Graphite / Metal diaphragm	Ball: Nickel alloy overlay Seat: Stellite	BX
			PTFE / PEEK seal ring	Ball: Nickel alloy overlay Seat: Stellite	BG	Slurries, pulp stock, steam, solid containing fluids, etc. ON-OFF or throttling, fire-safe.

1. Floating type for ASME Class 900 (DN 15 to 25) are available on request.
2. Extension bonnet is required for an automated valve which fluids temperature above 300°C and a manual valve which fluids temperature above 400°C.
3. Up to 450°C for oxidizing conditions.
4. Tungsten carbide or chrome carbide hardenings are available.
5. For the details of the code, please refer to KTM model coding system on page 8.
6. Trim code AY and AG are not available for ASME Class 600 and 900.

BALL SURFACE HARDENING PROCESS

Varieties of surface-hardened process for balls are available

Hardening	Hardness	Remarks
Hard chrome plating	HV800 or higher	Standard
Nickel alloy overlay	HV595 or higher	Standard
Tungsten carbide	HV1000 or higher	Please consult for details
Chrome carbide	HV800 or higher	Please consult for details

Other surface hardening processes are available on request.

KTM METALTITE® BALL VALVES

FLOATING AND TRUNNION TYPE

KTM'S METALTITE® FAMILY

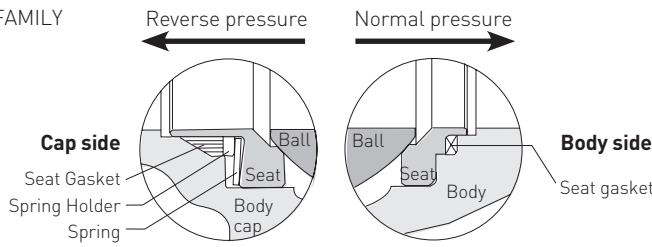

PRESSURE - TEMPERATURE RATING

Pressure - Temperature rating of valves are limited by sealing and stem materials. The combination of body rating and trim rating indicate the maximum valve rating at specific pressure and temperature conditions.

Metaltite® ball valves are available in bidirectional flow. As factory recommendation however, install valve with body cap to the downstream side when piping.

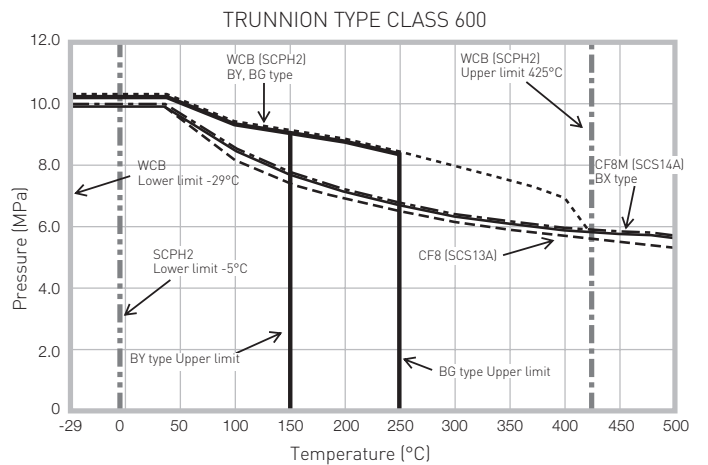
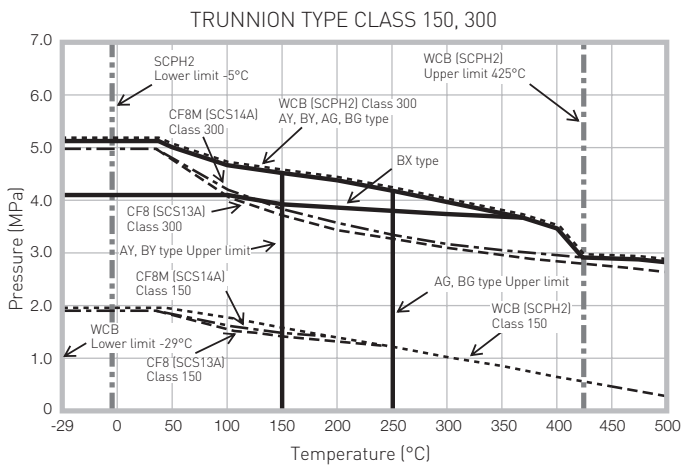
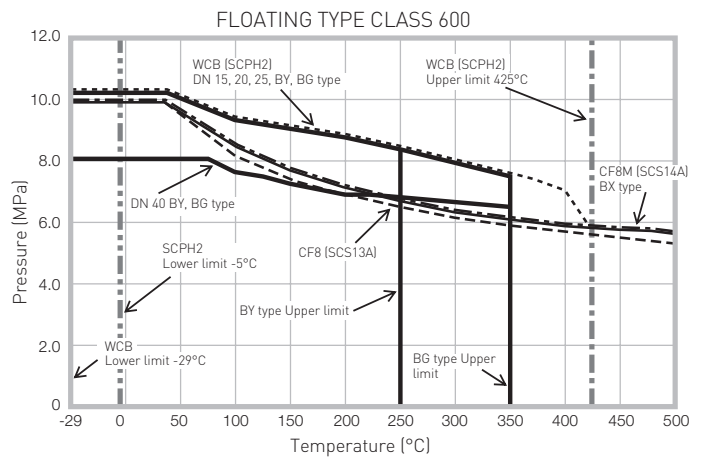
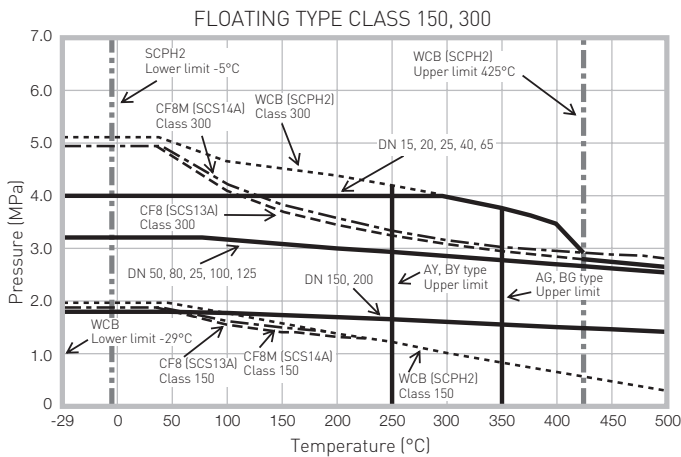

- Solid line — indicate trim rating.
- Dashed lines indicate body ratings.
 - WCB
 - CF8
 - CF8M
- Materials in parentheses indicate equivalent JIS material
- WCB subjected to PED certification is limited to minimum temperature -15°C

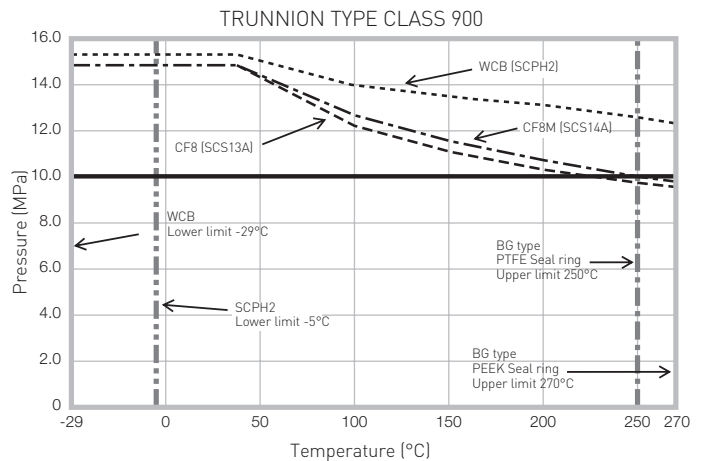

KTM METALTITE® BALL VALVES

FLOATING AND TRUNNION TYPE

FLOATING TYPE STRUCTURE (BIDIRECTIONAL FLOW)

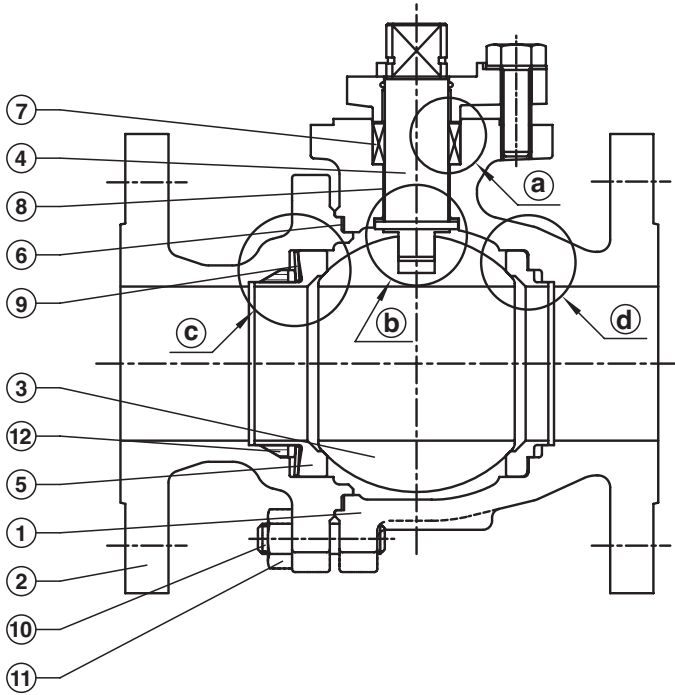

a GLAND AREA

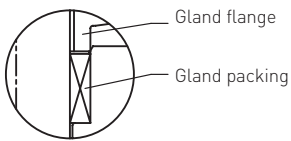

Gland packing is suitable for high-temperature service with fire-safe design (R-PTFE packing also available).

b STEM AREA

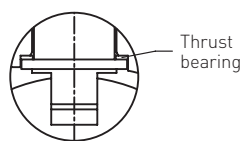

Stem with integral flange provides blow-out proof protection if packing is loosen.

c SEAT AREA (BODY-CAP SIDE)

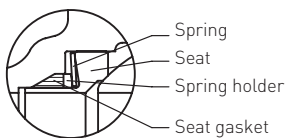

Seat spring provides flexibility to piping stress and thermal expansion to stabilize operation. Spring is isolated from fluid flow path, providing stable spring load.

d SEAT AREA (BODY SIDE)



Seat-gaskets are press-fitted into the body and provide stability for a wide range of temperatures from -29°C to 500°C*. *up to 450°C for oxidizing conditions.

KTM METALTITE® BALL VALVES

FLOATING AND TRUNNION TYPE

PARTS LIST (Floating type)

		ASME Class 150 Model EB11M / ASME Class 300 Model EB12M											
		Body material						Stainless steel ^[2]					
		Carbon steel			Material code								
		62-AY	62-BY	62-AG	62-BG	62-BX	32-AY	32-BY	32-AG	32-BG	32-BX		
		Temp. range											
No.	Parts name	-29°C ^[1] to 250°C			-29°C ^[1] to 350°C		Max. 425°C	-29°C to 250°C		-29°C to 350°C		Max. 500°C ^[3]	
1	Body	WCB [SCPH2]						CF8M [SCS14A]					
2	Body cap	WCB [SCPH2]						CF8M [SCS14A]					
3	Ball	CF8 [SCS13A] + HCr	CF8 [SCS13A] + SFNi	CF8 [SCS13A] + HCr	CF8 [SCS13A] + SFNi			CF8M [SCS14A] + HCr	CF8M [SCS14A] + SFNi	CF8M [SCS14A] + HCr	CF8M [SCS14A] + SFNi		
4	Stem	329SS [SUS329J1]				Nickel alloy		329SS [SUS329J1]				Nickel alloy	
5	Seat	316SS + Stellite						316SS + Stellite					
6	Gasket	RPTFE			Graphite			RPTFE		Graphite			
7	Gland packing	RPTFE			Graphite			RPTFE		Graphite			
8	Stem bearing	RPTFE			Graphite			RPTFE		Graphite			
9	Spring	316SS				Nickel alloy		316SS				Nickel alloy	
10	Stud bolt	A193 G B7						A193 G B8					
11	Nut	A194 G 2H						A194 G8					
12	Seat gasket	RPTFE			Graphite			RPTFE		Graphite			

		ASME Class 600 Model E0108M											
		Body material						Stainless steel ^[2]					
		Carbon steel			Material code								
		62-BY	62-BG	62-BX	32-BY	32-BG	32-BX						
		Temp. range											
No.	Parts name	-29°C ^[1] to 250°C			-29°C ^[1] to 350°C		Max. 425°C	-29°C to 250°C		-29°C to 350°C		Max. 500°C ^[3]	
1	Body	WCB [SCPH2]						CF8M [SCS14A]					
2	Body cap	WCB [SCPH2]						CF8M [SCS14A]					
3	Ball	304SS [SUS304] + SFNi						316 SS [SUS316] + SFNi					
4	Stem	329SS [SUS329J1] + ENP				Nickel alloy		329SS [SUS329J1]				Nickel alloy	
5	Seat	316SS + Stellite						316SS + Stellite					
6	Gasket	Spiral wounded gasket 316SS + Graphite						Spiral wounded gasket 316SS + Graphite					
7	Gland packing	RPTFE			Graphite			RPTFE		Graphite			
8	Stem bearing	RPTFE			Graphite			RPTFE		Graphite			
9	Spring	316SS				Nickel alloy		316SS				Nickel alloy	
10	Stud bolt	A193 G B7						A193 G B7 + Zn					
11	Nut	A194 G 2H						A194 G 2H + Zn					
12	Seat gasket	RPTFE			Graphite			RPTFE		Graphite			

- Lower limit temperature depending on the material
 - SCPH2: -5°C
 - WCB: -29°C (PED certified: -15°C)
- Stainless steel body CF8 / SCS13A (Material code 31) also available.
- Up to 450°C for oxidizing conditions.
 - Materials in parentheses indicate equivalent JIS material or generic name.
 - Floating type for ASME Class 900 (15 mm to 25 mm) also available. Please consult for the details.

SFNi: Nickel alloy overlay

HCr: Hard chrome plated

Zn: Zn plated

ENP: Electroless nickel plating

KTM METALTITE® BALL VALVES

FLOATING AND TRUNNION TYPE

TRUNNION TYPE STRUCTURE (BIDIRECTIONAL FLOW)

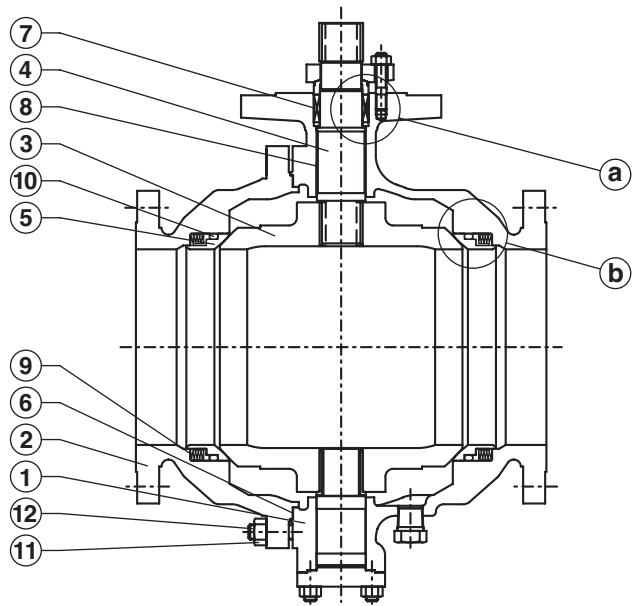

a GLAND AREA

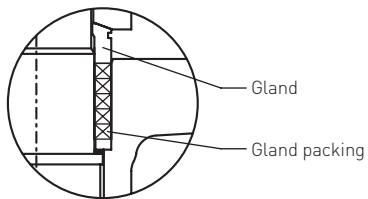

Graphite packing is suitable for fire-safe service (RPTFE packing also available).

b SEAT AREA

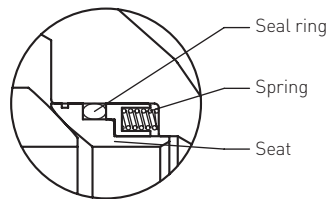

High corrosion-resistant PTFE seal ring or FKM O-ring provides excellent sealing performance.

KTM METALTITE® BALL VALVES

FLOATING AND TRUNNION TYPE

PARTS LIST (Trunnion type)

		ASME Class 150 Model E0105M, E0125M / ASME Class 300 Model E0106M, E0126M										
		Body material										
		Carbon steel					Stainless steel ^[2]					
		Material code										
		62-AY	62-BY	62-AG	62-BG	62-BX	32-AY	32-BY	32-AG	32-BG	32-BX	
		Temp. range										
No.	Parts name	-29°C ^[1] to 150°C			-29°C ^[1] to 250°C		Max. 425°C	-20°C to 150°C		-29°C to 250°C		Max. 500°C ^[3]
1	Body	WCB [SCPH2]					CF8M [SCS14A]					
2	Body cap	WCB [SCPH2]					CF8M [SCS14A]					
3	Ball	CF8 [SCS13A] + HCr	CF8 [SCS13A] + SFNi	CF8 [SCS13A] + HCr	CF8 [SCS13A] + SFNi		CF8M [SCS14A] + HCr	CF8M [SCS14A] + SFNi	CF8M [SCS14A] + HCr	CF8M [SCS14A] + SFNi		
4	Stem	403SS [SUS403] + HCr			Nickel alloy		329SS [SUS329J1]				Nickel alloy	
5	Seat	304SS + Stellite			304SS + Stellite		316SS + Stellite					
6	Gasket	RPTFE		Graphite			RPTFE		Graphite			
7	Gland packing	RPTFE		Graphite			RPTFE		Graphite			
8	Stem bearing	Metal back PTFE			Stellite		Metal back PTFE			Stellite		
9	Spring	316SS			Nickel alloy		316SS			Nickel alloy		
10	Seal ring	O-ring	PTFE seal ring		Graphite		O-ring	PTFE seal ring		Graphite		
11	Stud bolt	A193 G B7			A193 G B7 + Zn							
12	Nut	A194 G 2H			A194 G 2H + Zn							

		ASME Class 600 Model E0108M						ASME Class 900 Model E0109M		
		Body material								
		Carbon steel			Stainless steel ^[2]			Carbon steel	Stainless steel ^[2]	
		Material code								
		62-BY	62-BG	62-BX	32-BY	32-BG	32-BX	62-BG	32-BG	
		Temp. range								
No.	Parts name	-29°C ^[1] to 150°C	-29°C ^[1] to 250°C	Max. 425°C	-20°C to 150°C	-29°C to 250°C	Max. 500°C ^[3]	-5°C to 270°C	-29°C to 270°C	
1	Body	WCB [SCPH2]			CF8M [SCS14A]				WCB [SCPH2]	CF8M [SCS14A]
2	Body cap	WCB [SCPH2]			CF8M [SCS14A]				WCB [SCPH2]	CF8M [SCS14A]
3	Ball	CF8 [SCS13A] + SFNi			CF8M [SCS14A] + SFNi				CF8 [SCS13A] + SFNi	CF8M [SCS14A] + SFNi
4	Stem	403SS [SUS403] + HCr		Nickel alloy	329SS [SUS329J1]		Nickel alloy	329SS [SUS329J1]		
5	Seat	304SS + Stellite		329SS + Stellite	316SS + Stellite			304SS + Stellite	316SS + Stellite	
6	Gasket	Spiral wounded gasket 316 SS + Graphite			Spiral wounded gasket 316 SS + Graphite			Spiral wounded gasket 316 SS + Graphite		
7	Gland packing	RPTFE	Graphite			RPTFE	Graphite			
8	Stem bearing	Metal back PTFE	PEEK	Stellite	Metal back PTFE	PEEK	Stellite	PEEK		
9	Spring	316SS		Nickel alloy	316SS		Nickel alloy	316SS		
10	Seal ring	O-ring	PTFE seal ring		Graphite		O-ring	PTFE / PEEK seal ring		
11	Stud bolt	A193 G B7			A193 G B7 + Zn				A193 G B7	A193 G B7 + Zn
12	Nut	A194 G 2H			A194 G 2H + Zn				A194 G 2H	A194 G 2H + Zn

- Lower limit temperature depending on the material
 - SCPH2: -5°C
 - WCB: -29°C (PED certified: -15°C)
- Stainless steel body CF8 (Material code 31) also available.
- Up to 450°C for oxidizing conditions.
 - Materials in parentheses indicate equivalent JIS material or generic name.

SFNi: Nickel alloy overlay
 HCr: Hard chrome plated
 Zn: Zn plated

KTM METALTITE® BALL VALVES

FLOATING AND TRUNNION TYPE

FLOATING TYPE (FULL BORE)

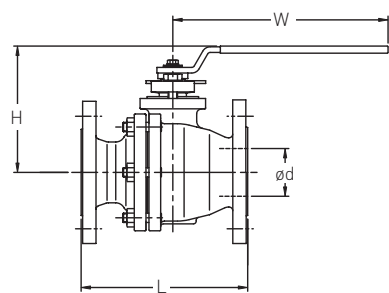

Size DN 15 to 100
Full bore

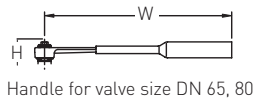

Handle for valve size DN 65, 80

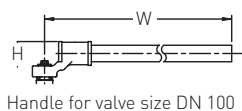

Handle for valve size DN 100

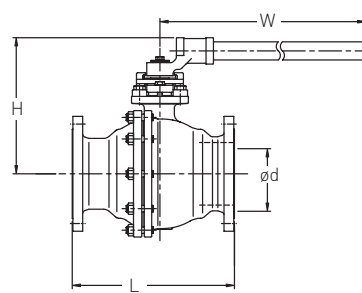

Size DN 125 to 200
Full bore

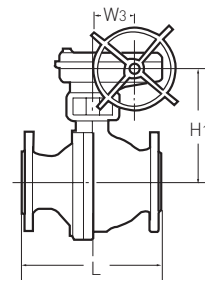
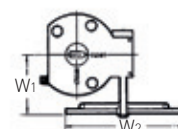

Size DN 150 to 200
Full bore

JIS10K / ASME CLASS 150 DIMENSIONS (mm)

Valve size (DN)	Ød	L	H	H ₁	W	Model EB11M					Gear weight (kg)
						Bare stem* weight (kg)	Gear type	W ₁	W ₂	W ₃	
15	13	108	81	-	200	2	-	-	-	-	-
20	19	117	85	-	200	3	-	-	-	-	-
25	25	127	98	-	240	5	-	-	-	-	-
40	38	165	125	-	350	9	-	-	-	-	-
50	51	178	135	-	350	11	-	-	-	-	-
65	64	190	165	-	600	18	-	-	-	-	-
80	76	203	174	-	600	21	-	-	-	-	-
100	102	229	240	-	1130	34	-	-	-	-	-
125	127	356	311	-	1740	63	-	-	-	-	-
150	152	394	331	348	1740	83	B	350	600	115.5	35
200	203	457	414	421	2345	132	C	420	800	171.0	74

* Bare stem: Valve without gear, operation parts, actuator.

JIS20K / ASME CLASS 300 DIMENSIONS (mm)

Valve size (DN)	Ød	L	H	H ₁	W	Model EB12M					Gear weight (kg)
						Bare stem* weight (kg)	Gear type	W ₁	W ₂	W ₃	
15	13	140	81	-	200	3	-	-	-	-	-
20	19	152	85	-	200	4	-	-	-	-	-
25	25	165	98	-	240	6	-	-	-	-	-
40	38	190	125	-	350	12	-	-	-	-	-
50	51	216	135	-	350	17	-	-	-	-	-
65	64	241	165	-	600	26	-	-	-	-	-
80	76	283	174	-	600	33	-	-	-	-	-
100	102	305	240	-	1130	53	-	-	-	-	-
125	127	381	311	-	1740	77	-	-	-	-	-
150	152	403	331	348	1740	116	B	350	600	115.5	35
200	203	502	414	421	2345	187	C	420	800	171.0	74

* Bare stem: valve without gear, operation parts, actuator.

ASME CLASS 600 DIMENSIONS (mm)

Valve size (DN)	Ød	Model E0108M				
		RF	L	RJ	H	W
15	13	165	-	163	98	240
20	19	190	-	190	105	240
25	25	216	-	216	124	350
40	38	241	-	241	134	350

C_v VALUES

Valve size (DN)	Floating type		Trunnion type	
	Full bore	Valve size (DN)	Full bore	Valve size (DN)
15	26	50	480	
20	50	80	1300	
25	94	100	2300	
40	260	150	5400	
50	480	200	10000	
65	750	250	16000	
80	1300	300	24000	
100	2300	350	31400	
125	3800	400	43000	
150	5400	450	57000	
200	10000	500	73000	

• Floating type for ASME Class 900 (DN 15 to 25) are available on request.

KTM METALTITE® BALL VALVES

FLOATING AND TRUNNION TYPE

TRUNNION TYPE (FULL BORE)

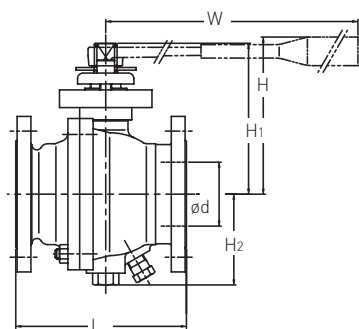

Sizes DN 50 to 100
Full bore

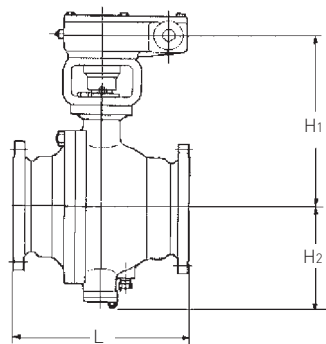

Sizes DN 150 and larger
Full bore

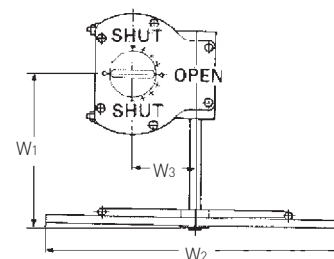

JIS10K / ASME CLASS 150 DIMENSIONS (mm)

Valve size (DN)	Ød	L	H	H ₁	H ₂	W	Model E0125M					Gear weight (kg)
							Bare stem* weight (kg)	Gear type	W ₁	W ₂	W ₃	
50	51	178	154	131	81	350	13	-	-	-	-	-
80	76	203	193	186	108	600	31	-	-	-	-	-
100	102	229	254	210	132	1065	44	-	-	-	-	-
150	152	394	-	386	207	-	133	B	350	600	115.5	35
200	203	457	-	448	265	-	229	C	420	800	171.0	74

Valve size (DN)	Ød	L	Carbon steel		Stainless steel		Bare stem* weight (kg)	Gear type	W ₁	W ₂	W ₃	Gear weight (kg)
			H ₁	H ₂	H ₁	H ₂						
250	254	533	521	325	521	335	330	C	420	800	171.0	74
300	305	610	580	365	580	385	490	C	420	800	171.0	74
350	337	686	659	400	714	430	605	D	400	800	257.0	145
400	387	762	699	440	717	470	891	D	400	800	257.0	145
450	438	864	769	500	767	520	1122	E	450	800	354.5	150
500	489	914	964	555	972	590	1408	H1	410	800	150.0	207

* Bare stem: valve without gear, operation parts, actuators.

KTM METALTITE® BALL VALVES

FLOATING AND TRUNNION TYPE

JIS20K / ASME CLASS 300 DIMENSIONS (mm)

Model E0126M												
Valve size (DN)	Ød	L	H	H ₁	H ₂	W	Bare stem* weight (kg)	Gear type	W ₁	W ₂	W ₃	Gear weight (kg)
50	51	216	154	131	81	350	20	-	-	-	-	-
80	76	283	193	186	108	600	40	-	-	-	-	-
100	102	305	254	210	132	1065	73	-	-	-	-	-
150	152	403	-	386	207	-	169	B	350	600	115.5	35
200	203	502	-	448	265	-	286	C	420	800	171.0	74

Model E0106M												
Valve size (DN)	Ød	L	Carbon steel		Stainless steel		Bare stem* weight (kg)	Gear type	W ₁	W ₂	W ₃	Gear weight (kg)
			H ₁	H ₂	H ₁	H ₂						
250	254	568	521	325	521	335	402	C	420	800	171.0	74
300	305	648	619	365	619	385	583	D	400	800	257.0	145
350	337	762	659	400	664	430	814	E	450	800	354.5	150
400	387	838	699	440	717	470	1133	E	450	800	354.5	150
450	438	914	904	500	902	520	1408	H1	410	800	150.0	207
500	489	991	964	555	972	590	1694	H1	410	800	150.0	207

* Bare stem: valve without gear, operation parts, actuators.

ASME CLASS 600 DIMENSIONS (mm)

Model E0108M												
Valve size (DN)	Ød	L		H	H ₁	H ₂	W	Gear type	W ₁	W ₂	W ₃	
		RF	RJ									
50	51	292	295	192	-	132	600	-	-	-	-	
80	76	356	359	253	-	143	1130	-	-	-	-	
100	102	432	435	-	350	173	-	B	350	600	115.5	
150	152	559	562	-	454	242	-	C	420	800	171.0	
200	203	660	664	-	534	312	-	D	400	800	257.0	
250	254	787	791	-	632	377	-	E	450	800	354.5	
300	305	838	841	-	763	440	-	H1	410	800	150.0	
350	337	889	892	-	806	490	-	H1	410	800	150.0	
400	387	991	994	-	-	514	-	-	-	-	-	

- Reduced bore are available, please consult us for details.
- Trunnion type for ASME Class 900 (DN 40 to 300) are available on request.

KTM METALTITE® BALL VALVES

FLOATING AND TRUNNION TYPE

KTM MODEL CODING SYSTEM

Example:			EB11	M	E	62	AY	A15	SF	150	E2						
Valve code	Class	Description															
	ASME	JIS															
EB11	150	10K	Full bore Floating type DN 15 to 200														
EB12	300	20K	Full bore Floating type DN 15 to 200														
E0105 (E1101)	150	10K	Full bore Trunnion type DN 250 to 500														
E0106 (E1102)	300	20K	Full bore Trunnion type DN 250 to 500														
E0125 (E1125)	150	10K	Full bore Trunnion type DN 50 to 200														
E0126 (E1126)	300	20K	Full bore Trunnion type DN 50 to 200														
E0108 (E1108)	600	-	Full bore Floating type DN 15 to 400														
E0108 (E1108)	600	-	Full bore Trunnion type DN 50 to 400														
E0109 (E1109)	900	-	Full bore Trunnion type DN 40 to 300														
* Model in parentheses: Apply to Extension bonnet type.																	
Sub code	Description																
M	Metal seated																
Special feature	Description																
Blank	Not applicable																
E	Extension bonnet (For model code EB)																
K	Powder service																
Body code	Description																
	JIS	ASTM															
31	SCS13A (304SS)	CF8 (304SS)															
32	SCS14A (316SS)	CF8M (316SS)															
62	SCPH2	WCB															
Trim code	See trim code table																
Flange code	Description																
ASME	Description	ASME	Description	JIS	Description												
A15	ASME Class 150	A60	ASME Class 600	J10	JIS 10K												
A30	ASME Class 300	A90	ASME Class 900	J20	JIS 20K												
(JPI also available)																	
Connection code	Description																
RF	Raced face																
RJ	Ring joint																
SF	Smooth finish 125 to 250 AARH																
Size code	15	20	25	40	50	65	80	100	125	150	200	250	300	350	400	450	500
DN	15	20	25	40	50	65	80	100	125	150	200	250	300	350	400	450	500
NPS	1/2	3/4	1	1 1/2	2	2 1/2	3	4	5	6	8	10	12	14	16	18	20
Option code	Description																
Blank	No additional option																
E2	Extension bonnet for high temperature (For model code EB)																
E4	Extension bonnet for high temperature (For other than model code EB)																

TRIM CODE

	Ball			Seat ⁽⁴⁾	Packing	Stem ⁽⁴⁾
	JIS	ASTM				
AY⁽¹⁾	SCS13A / HCr ⁽²⁾ or SCS14A / HCr ⁽³⁾	CF8 / HCr ⁽²⁾ or CF8M / HCr ⁽³⁾		SS+stellite	RPTFE	-
BY	SCS13A / SFNi ⁽²⁾ or SCS14A / SFNi ⁽³⁾	CF8 / SFNi ⁽²⁾ or CF8M / SFNi ⁽³⁾		SS+stellite	RPTFE	-
AG⁽¹⁾	SCS13A / HCr ⁽²⁾ or SCS14A / HCr ⁽³⁾	CF8 / HCr ⁽²⁾ or CF8M / HCr ⁽³⁾		SS+stellite	Graphite	-
BG	SCS13A / SFNi ⁽²⁾ or SCS14A / SFNi ⁽³⁾	CF8 / SFNi ⁽²⁾ or CF8M / SFNi ⁽³⁾		SS+stellite	Graphite	-
BX	SCS13A / SFNi ⁽²⁾ or SCS14A / SFNi ⁽³⁾	CF8 / SFNi ⁽²⁾ or CF8M / SFNi ⁽³⁾		SS+stellite	Graphite	-

1. Trim code AY and AG are not available for Class 600 and 900
2. For body code 31 and 62
3. For body code 32
4. For the details, please refer to 'Parts list' on page 4, 5

HCr: Hard chrome plating
SFNi: Nickel alloy overlay